

# Mounting instruction upper flap for Hamburger top

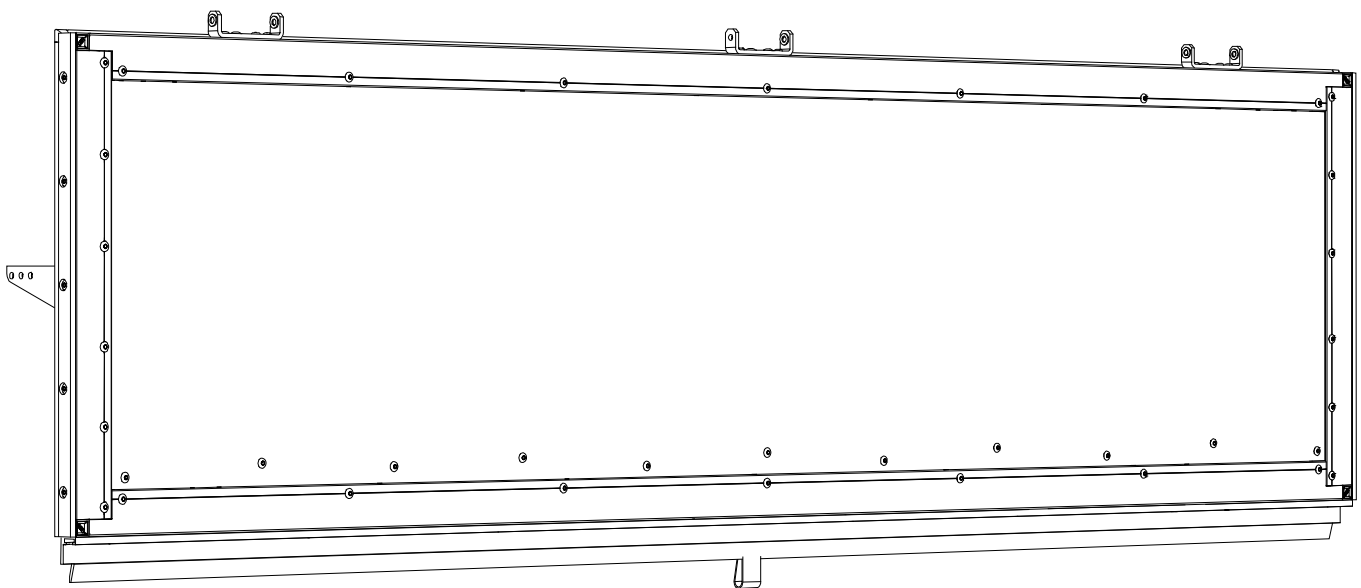

Translation of the original mounting instruction

 **Contents**

|   |           |
|---|-----------|
| <b>1 General</b> .....  | <b>03</b> |
| <b>2 Safety</b> .....   | <b>05</b> |
| <b>3 Calculation sheet</b> .....  | <b>06</b> |
| <b>4 Mounting of the crossbar</b> .....                                       | <b>07</b> |
| <b>5 Mounting of double joints</b> .....                                      | <b>08</b> |
| <b>6 Mounting of the top parts</b> .....                                      | <b>09</b> |
| <b>7 Mounting of rain and cover strip (normally done by tarp maker)</b> ..... | <b>10</b> |
| <b>8 Mounting of the rubber clamping strip</b> .....                          | <b>11</b> |
| <b>9 Mounting of retainers and water drip</b> .....                           | <b>12</b> |
| <b>10 Mounting of gas pressure springs to the fixing brackets</b> .....       | <b>13</b> |
| <b>11 Mounting of upper flap to the crossbar</b> .....                        | <b>14</b> |
| <b>12 Mounting of gas pressure springs to the upper flap</b> .....            | <b>15</b> |
| <b>13 Annexes</b> .....   | <b>16</b> |

## GENERAL REMARKS

### Introduction to Mounting Instruction

Alteration service: Yes

Staff: According to curriculum for apprenticeship as a body and vehicle mechanic and a body and vehicle construction mechanic.

This Mounting Instruction is part of the delivery and an important help for successful mounting. Therefore, it must be available to the mechanic during the mounting works.

Furthermore, the assembly guidelines of the applicable vehicle producers must be obeyed.

### Copyright:

The copyright for this mounting instruction is reserved by TSE Trailer System Engineering GmbH & Co. KG

If you need any further information, do not hesitate to contact us:

TSE Trailer System Engineering GmbH & Co. KG  
Bei der Mühle 4  
72365 Ratshausen  
Germany  
Phone: +49 (0)7427 / 92 33-0  
Fax: +49 (0)7427 / 92 33-75  
Email: [verkauf@tse-trailersystems.de](mailto:verkauf@tse-trailersystems.de)  
Homepage: [www.tse-trailersystems.de](http://www.tse-trailersystems.de)

### Instruction and training support

As an employer, you are obliged to inform and instruct your personnel about existing legal and accident prevention regulations.

The personnel must have understood these instructions, and it must be safeguarded that the instructions are obeyed.

Only in this way you will reach safety and danger awareness of your personnel at work.

### Example for training topics

#### 1. About safety

- Accident prevention regulations
- General legislation
- General safety hints
- Measures in emergency cases
- Personal protective equipment

#### 2. Maintenance and repair regulations

- Correct use of cleaning agents and lubricants
- Special experience of the mechanic in maintenance, repair, cleaning and upkeep of the product

## Hints

**Attention:**

The surfaces of the TSE modules must not be contaminated with caustic cleaning fluids. Cleaning fluids with the appropriate labeling are aggressive and can cause damage to all component surfaces. These should expressly not be used for gentle cleaning.

| Nummer | Symbol      |
|--------|-------------|
| GHS05  | corrosivity |
|        |             |

**ATTENTION!**

Texts with this symbol will warn you against possible mistakes in mounting and, therefore, against potential material damages.

**HINT!**

Texts with this symbol will give you tips or additional information.

**TIGHTENING TORQUE!**

Texts with this symbol will give you necessary tightening torques.

**You need holes!**

Texts with this symbol indicate the setting of holes.

# Safety

## General

Although our products are in accordance with the state of the art, they may pose a risk if:

- they are mounted by unskilled personnel
- they are maintained improperly.

## Safety hints

This safety instruction informs you about the products of TSE Trailer System Engineering GmbH & Co. KG. It contains information about maintenance and repair of the parts and their components. The service instruction has only been written for skilled personnel of qualified and authorized specialized companies in motor vehicle crafts. The service instruction is not applicable for other target groups.

We want to support specialized companies with the present mounting instruction during the mounting works with our products.

TSE Trailer System Engineering GmbH & Co. KG accepts no liability for the installation of inapplicable or unreleased parts in their products.

Defects due to wrong handling, aggressive cleaning agents, use of force or subsequent changes of the delivered product or single components of it, as well as non-observance of the safety hints and consequential damages caused thereby, are not covered by our warranty.

Only use unchanged original parts and accessories supplied by the manufacturer.

We do not accept any warranty for the correctness, completeness or currency of the given information. The contents and information of this mounting instruction are neither a warranty or warranted characteristics within the meaning of German legislation, respectively the German Civil Code (Bürgerliches Gesetzbuch (BGB)), nor can they be interpreted as such.

No claims can be derived from provision of information, recommendation or consulting. Liability for damages is generally excluded as far as we are not responsible in the sense of intent or gross

negligence, or as far as this does not contradict mandatory legal provisions.

Texts and graphics are subject to our rights of use; copy rights or right of distribution in any form require our agreement.

Mentioned brand names, even if they are not marked as such in every case, are still subject to the regulations of the trade mark law.

If any disputes of legal nature occur from applying information found in this mounting instruction, they shall solely be subject to the regulations of German law.

The Amtsgericht Stuttgart (Local Court in Stuttgart) is deemed to be agreed on as place of jurisdiction. If some clauses of this declaration about limitation of liability do not or no longer comply with the applicable legal provisions, the validity of the other clauses shall remain unaffected thereof. Read the information in this mounting instruction carefully. Especially, obey the hints for your own safety.

All technical information, descriptions and pictures shall be valid from the day of their printing - respectively the day of any supplements hereto - on.

We reserve the right to make changes due to steady further development.

No claims can be derived from applications and explanations of this publication.

### **Safety hints for the technician:**

Unauthorized people are not allowed to enter the vehicle and the area around it.

Your working area should be in good order.

Only works which you are commissioned and acquainted with have to be executed.

Increased caution is advisable in dangerous areas.

Obey the producer's information and safety hints for the applicable product when you deal with operation materials (oils, grease etc.).

Only applicable lifting devices may be used.

### Calculation sheet

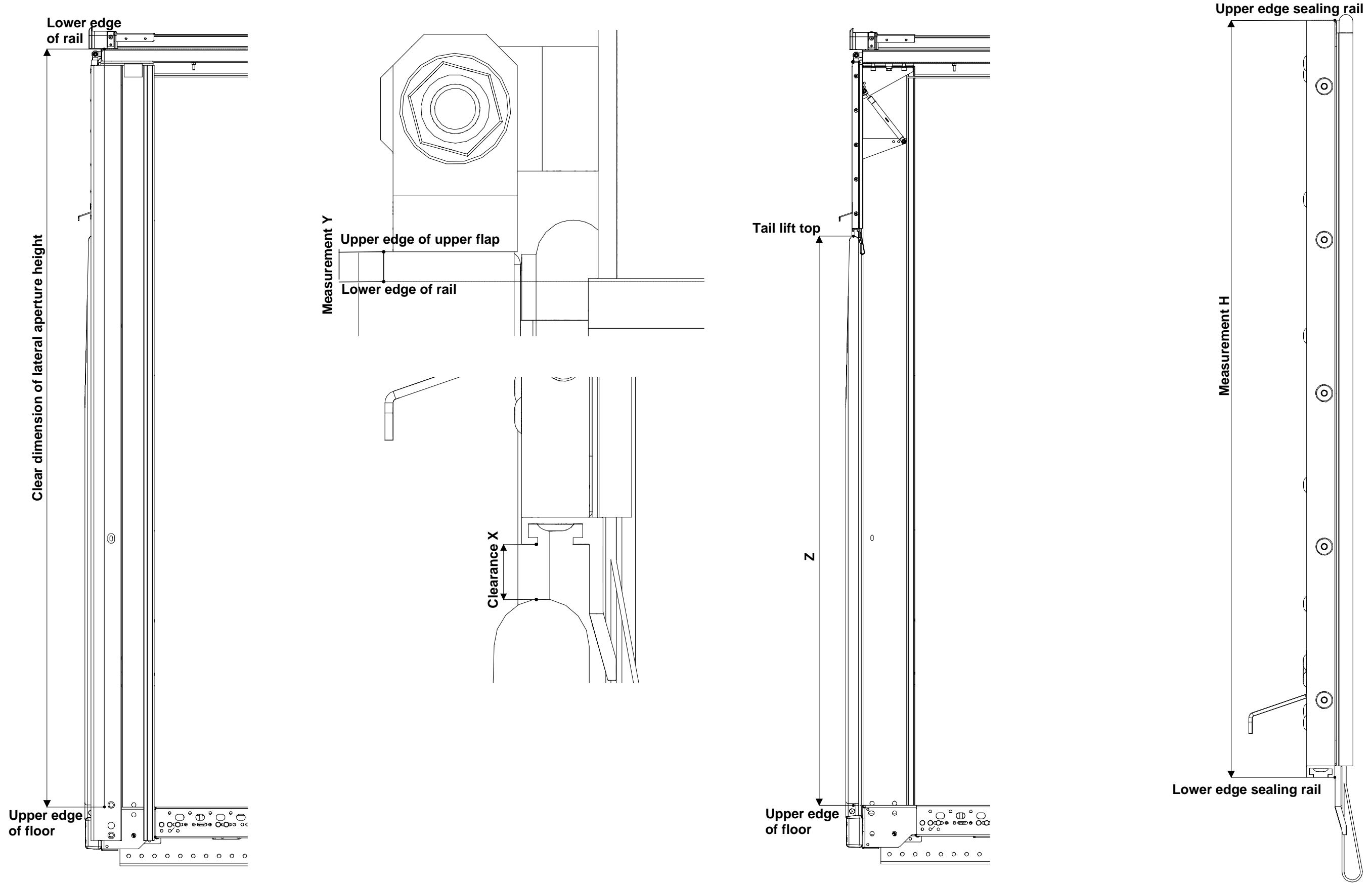

The length of the upper flap (measurement H) is calculated as follows:  
 Lateral aperture height + differential dimension Y (10mm) – measurement of clearance X (20mm) – tail lift top to upper edge of floor (Z) = upper flap length (measurement H)

## Mounting of the crossbar

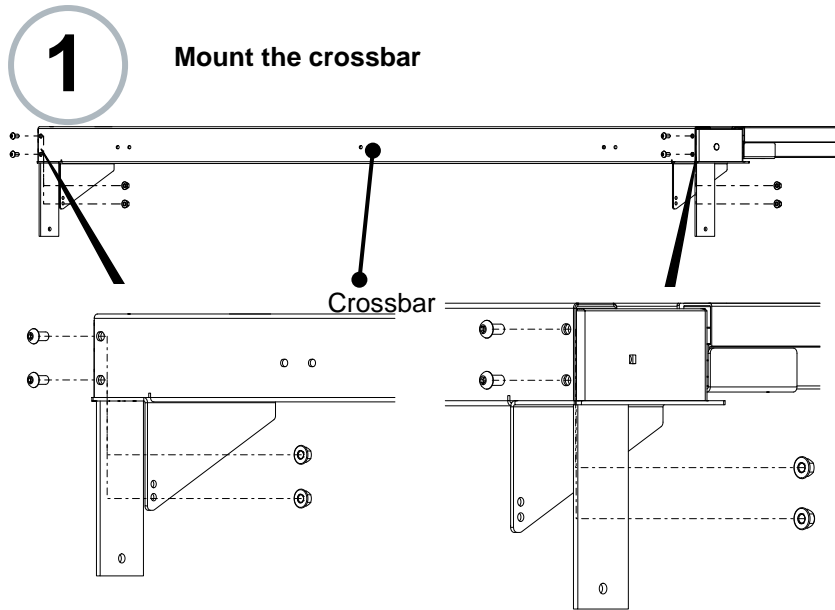

 Lens-head screw M10x20

 Hexagon nut M10

 **Torque 71 Nm**

Screws and nuts are part of the **Hamburger upper flap crossbar complete (TSE-No.: 1302252)**.

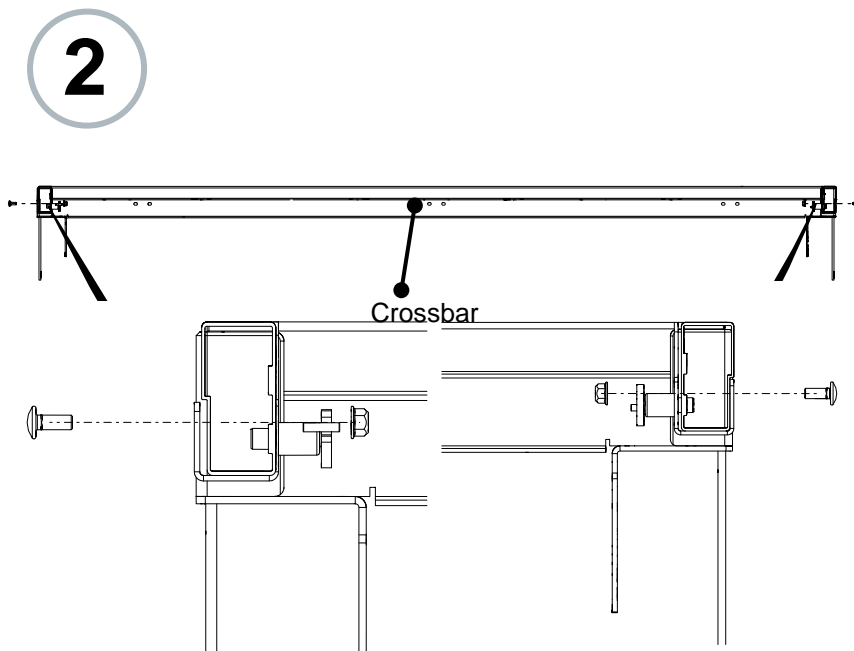

 Carriage bolt M8x20

 Hexagon nut M8

 **Torque 25 Nm**

Screws and nuts are part of the **Hamburger upper flap crossbar complete (TSE-No.: 1302252)**.

## Mounting of double joints

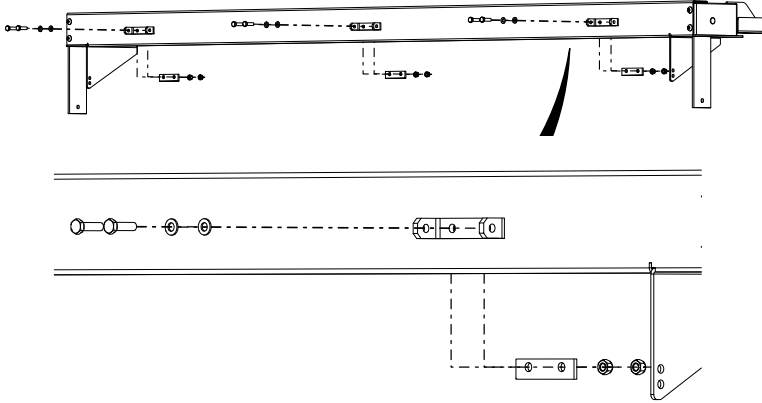
**1**
**Mount the double joint**

Hexagon screw M8x30



Washer A8.4



KIT2 Double joint



KIT2 Clamping plate upper flap



Hexagon nut M8

**Torque 25 Nm**

Screws, washers, double joints, clamping plates and washers are part of the **applicable accessories of the upper flap.**



Do not yet fix the double joints tightly, as the setting of the upper flap will be done later.



## Mounting of the top parts

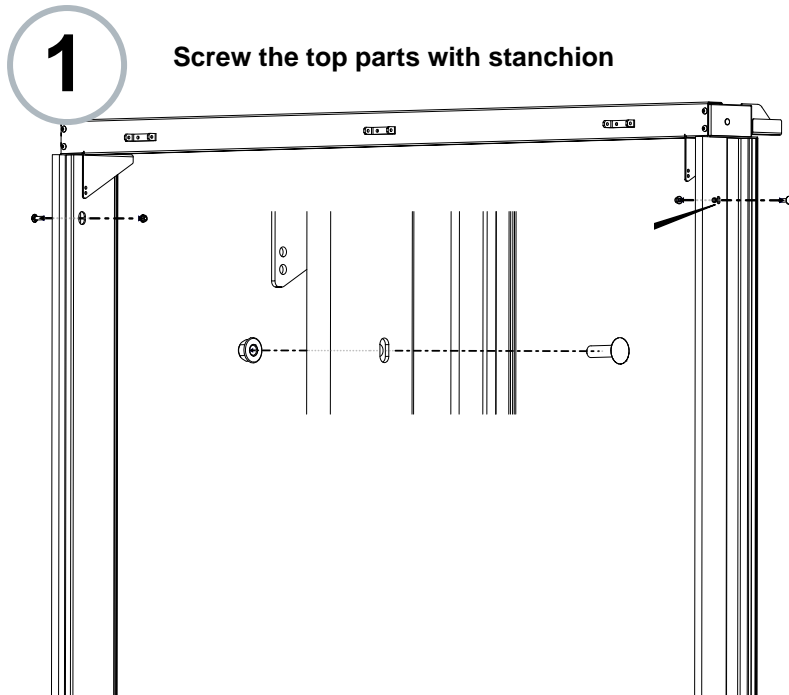

Carriage bolt M10x35



Hexagon nut M10



**Torque 48 Nm**

Screws and nuts are part of the **Hamburger upper flap crossbar complete** (TSE no.: 1302252).



**This screw must be well ened by all means.**

## Mounting of rain and cover strip (normally done by tarp maker)

**1****Mount the rain and cover strip**

Cover strip for the rain strip

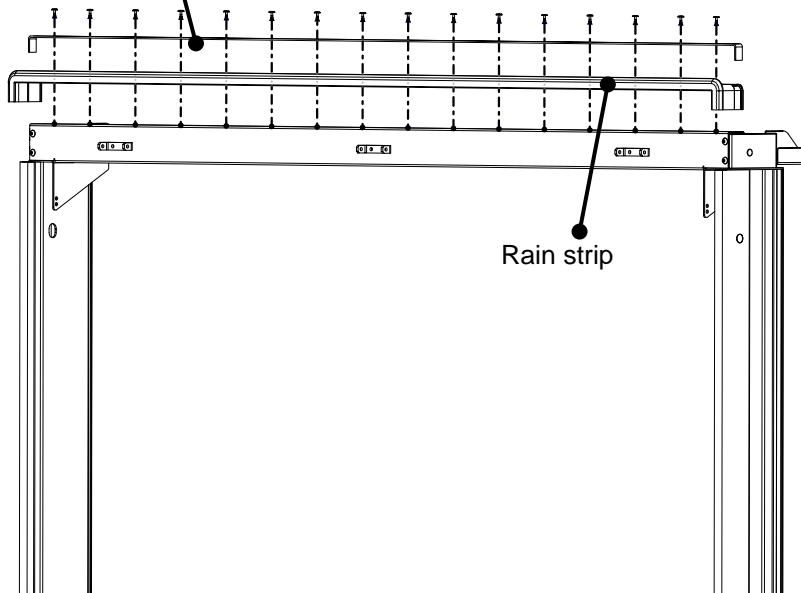



Rain strip



Aluminium rivet

Rain and cover strip are part of the **Hamburger upper flap crossbar complete** (TSE no.: 1302252).

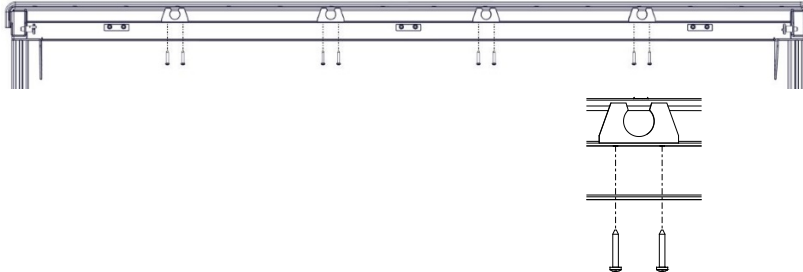
## Mounting of the rubber clamping strip

**1****Mount the rubber clamping spring** Rubber clamping spring Pan Head M6x40

Rubber clamping springs and pan head are part of the **Hamburger upper flap crossbar complete (TSE-no.: 1302252)**.

## Mounting of retainers and water drip

1

Screw on retainers

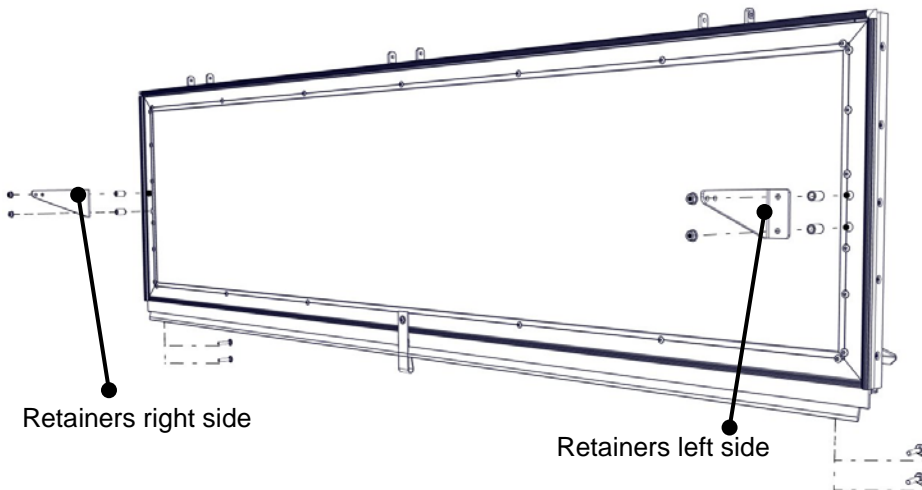

Carriage bolt without nut  
M8x45



Hexagon nut with flange  
M8



Distance sleeve

Retainers on the left side,  
Retainers on the right side,  
screws and distance sleeves  
are part of the **applicable  
accessories of the upper  
flap.**

2

Rivet the water drip

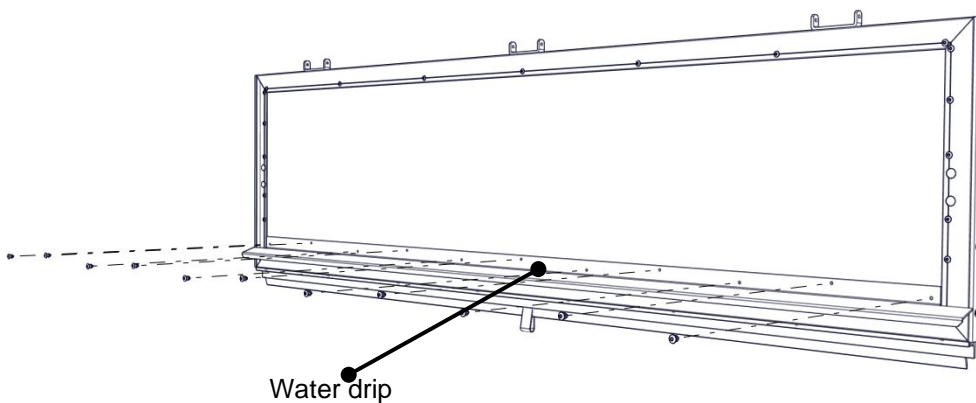

Hemlok rivet  
KL-BER4.8-6.8mm

Water drip and rivets are  
part of the **applicable  
accessories of the upper  
flap.**

The borings for the water  
drip as well as sealing  
measures at diverted  
interfaces are executed by  
the customer.

## Mounting of gas pressure springs to the fixing brackets

1

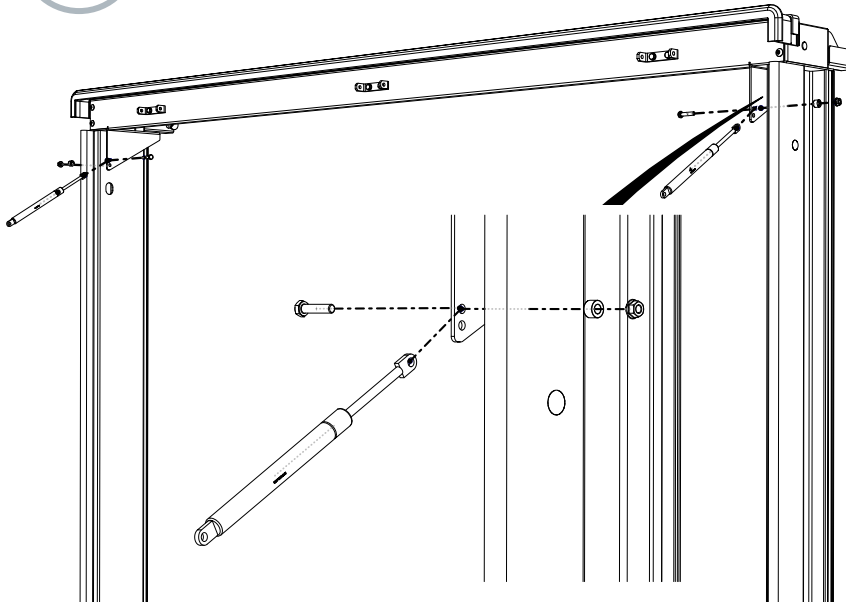

Hexagon screw M8x35



KIT2 sleeve upper flap



Hexagon nut M8



**Torque 25 Nm**

Screws, washers, sleeves are part of the **applicable accessories of the upper flap.**



Tighten the screws with a wrench and a torque wrench. Then open it again with ¼ turn backwards.

## Mounting of upper flap to the crossbar

1

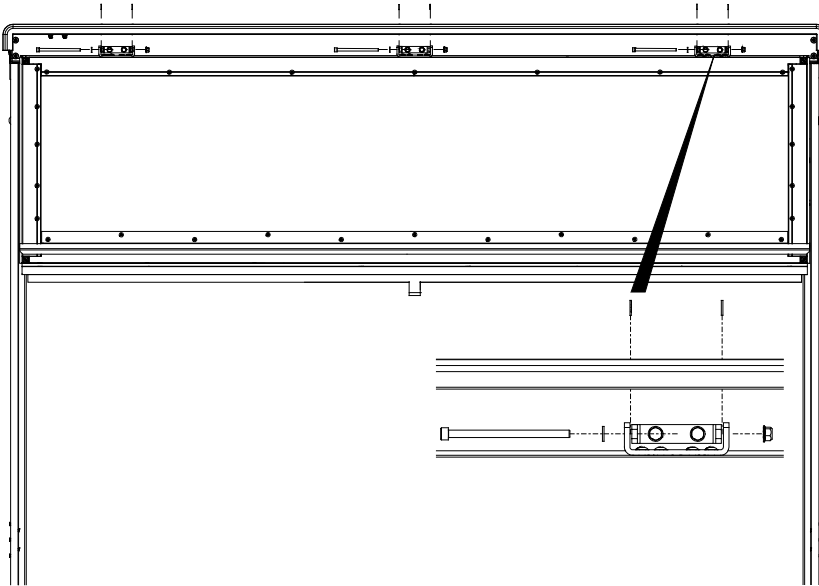

Cylinder screw M8x130



Washer A8.4



Hexagon nut M8



**Torque 36 Nm**

Screws, washers, sleeves and nuts are part of the **applicable accessories of the upper flap.**



Tighten the screws with a wrench and a torque wrench. Then open it again with  $\frac{1}{4}$  turn backwards.

**From this step of mounting on, three employees must be present during the mounting works!!!**

## Mounting of gas pressure springs to the upper flap

1

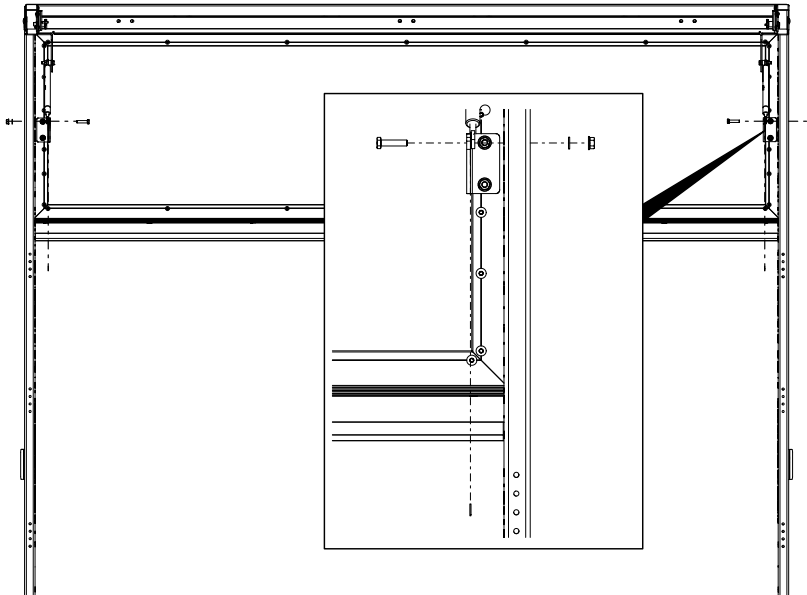

Hexagon screw M8x35



Washer A8.4



KIT2 sleeve upper flap



Hexagon nut M8



**Torque 25 Nm**

Screws, washers, sleeves and nuts are part of the **applicable accessories of the upper flap.**



Tighten the screws with a wrench and a torque wrench. Then open it again with ¼ turn backwards.

**Now the upper flap has to be adjusted by means of the double joints at the crossbars. Hereby, there may only be a distance of 5mm to the stanchions at the left and at the right side. If the distance fits this way, the double joints at the crossbar are tightened.**





## Revision level

| Revision Level | Kind of change                           | Date              | Name         |
|----------------|--|-------------------|--------------|
| 00             | New creation of mounting instruction     | 14 May 2019       | Laib / Maier |
| 01             | Mounting of the holders has been changed | 30. March 2020    | Laib / Maier |
| 02             | Corrected tightening torques             | 29 September 2020 | Boll         |
| 03             | Page 4 changed                           | 23.11.2020        | Boll         |

| Erstellt                            | Geprüft und Freigegeben               |
|-------------------------------------|---------------------------------------|
| Datum:<br>Name/Abt.<br>Unterschrift | Datum: 29.09.2020<br>Name/Abt. U.Boll |
| Dokument: FB45120A                  |                                       |