

Repair instruction

Liftmaster and compact hydraulics front wall IV

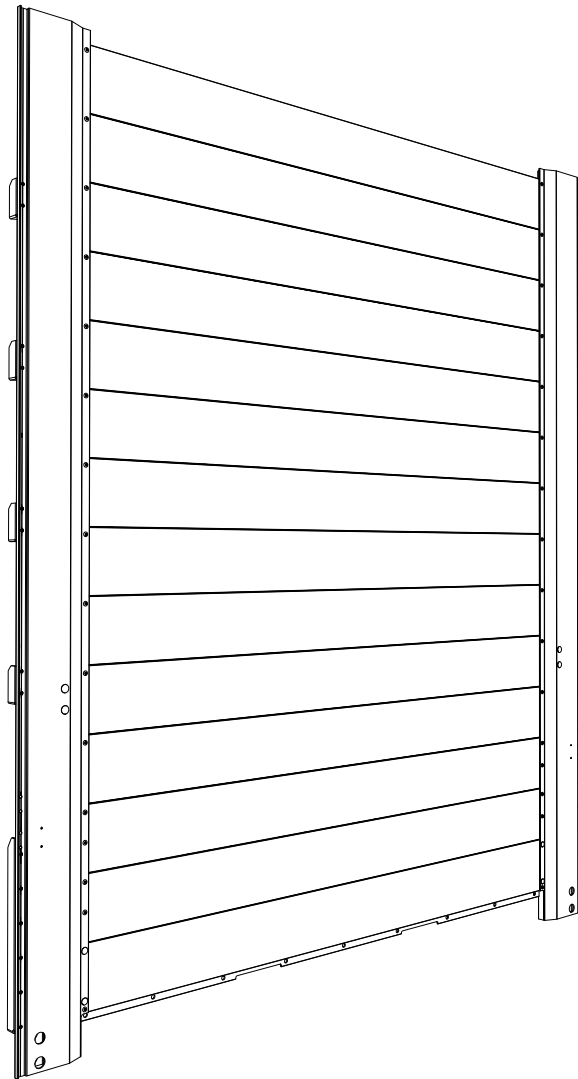

Translation of the original repair instruction



Contents

1 General remarks	03
2 Safety.....	05
3 Dismantling of Liftmaster front wall IV	06
4 Mounting of Liftmaster front wall IV	09
5 Dismantling of compact hydraulics front wall IV.....	11
6 Mounting of compact hydraulics front wall IV	13
7 Ventilation of the compact hydraulics	15
8 Annexes	16

GENERAL REMARKS

Introduction to Mounting Instruction

Alteration service: Yes

Staff: According to curriculum for apprenticeship as a body and vehicle mechanic and a body and vehicle construction mechanic.

This Mounting Instruction is part of the delivery and an important help for successful mounting. Therefore, it must be available to the mechanic during the mounting works.

Furthermore, the assembly guidelines of the applicable vehicle producers must be obeyed.

Copyright:

The copyright for this mounting instruction is reserved by TSE Trailer System Engineering GmbH & Co. KG
If you need any further information, do not hesitate to contact us:

TSE Trailer System Engineering GmbH & Co. KG
Bei der Mühle 4
72365 Ratshausen
Germany
Phone: +49 (0)7427 / 92 33-0
Fax: +49 (0)7427 / 92 33-75
Email: verkauf@tse-trailersystems.de
Homepage: www.tse-trailersystems.de

Instruction and training support

As an employer, you are obliged to inform and instruct your personnel about existing legal and accident prevention regulations.

The personnel must have understood these instructions, and it must be safeguarded that the instructions are obeyed.

Only in this way you will reach safety and danger awareness of your personnel at work.

Example for training topics

1. About safety
 - Accident prevention regulations
 - General legislation
 - General safety hints
 - Measures in emergency cases
 - Personal protective equipment
2. Maintenance and repair regulations
 - Correct use of cleaning agents and lubricants
 - Special experience of the mechanic in maintenance, repair, cleaning and upkeep of the product

Hints

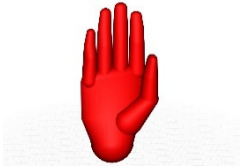

Attention

Texts with this symbol will warn you against possible mistakes in mounting and, therefore, against potential material damages.

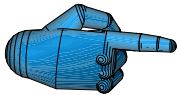

HINT!

Texts with this symbol will give you tips or additional information.



TIGHTENING TORQUE

Texts with this symbol will give you the necessary tightening torques.

Safety

General

Although our products are in accordance with the state of the art, they may pose a risk if:

- they are mounted by unskilled personnel
- they are maintained improperly.

Safety hints

This service instruction informs you about the products of TSE Trailer System Engineering GmbH & Co. KG. It contains information about maintenance and repair of the installation and your components. The service instruction has exclusively been written for trained specialized personnel of qualified and authorized specialized companies in the vehicle handicraft business. This service instruction is not applicable to other target groups.

With this provided mounting instruction, we want to support specialized companies in installation works of our products.

TSE Trailer System Engineering GmbH & Co. KG does not accept any responsibility for the installation of unsuitable or unreleased parts into their product. We do not accept any warranty for the provided information in regard to correctness, completeness or currency.

The contents and information in this mounting instruction are no guarantee or warranted characteristics in the sense of German legislation or the BGB (German Civil Code), and they cannot be interpreted as such.

Claims on information, recommendation or advice cannot be derived from this provision. Warranty for damages is generally excluded as far as it is not due to willful intent or gross negligence from our side, or as far as no other mandatory legal provisions restrict this exclusion.

Texts and graphs are subject to our rights of usage, so copying or dissemination in any form require our agreement.

Mentioned brand marks, even if they are not marked as such in each case, are still subject to the regulations of brand mark rights.

If any differences of legal kind occur from the use of information in this mounting instruction, they shall only be subject to the regulations of German legislation.

The Amtsgericht Stuttgart (regional court in Stuttgart) is agreed as place of jurisdiction. If some clauses of this limitation of warranty do not - or do not any longer - comply with the applicable legal regulations, the validity of the other clauses shall not be affected. Please, read the information in this mounting instruction carefully. Especially, consider the hints to your safety.

All technical information, descriptions and pictures apply from the day of going to press on, respectively from the day of their supplements on.

We reserve the right of continuous development of the information.

No claims can be derived from versions of this brochure.

Safety hints for the mechanic:

Unauthorized persons are not allowed to enter the vehicle.

Your working area should be in good order.

You should only execute works you are commissioned for and you are familiar with.

Increased caution is required in the dangerous areas.

Please, obey the producer specifications and safety hints for the applicable product when handling operating materials (oil, grease, etc.).

Only applicable lifting devices may be used.

Dismantling Liftmaster front wall IV

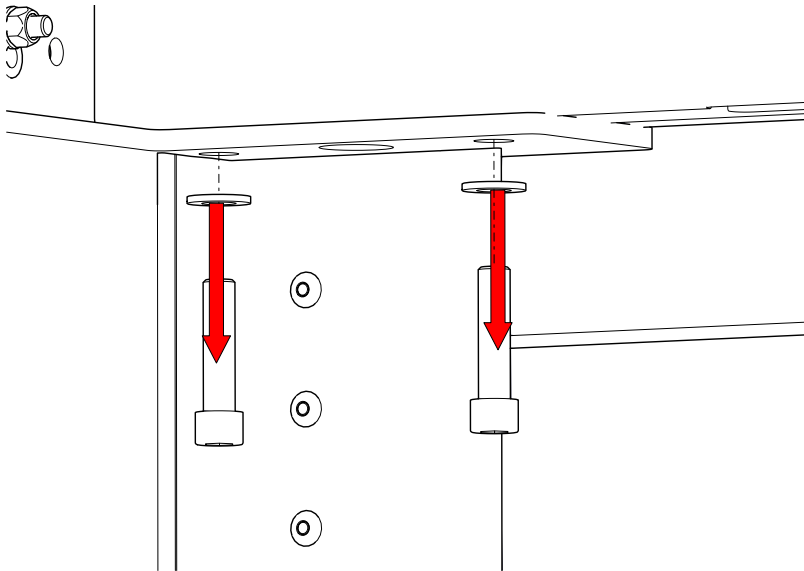
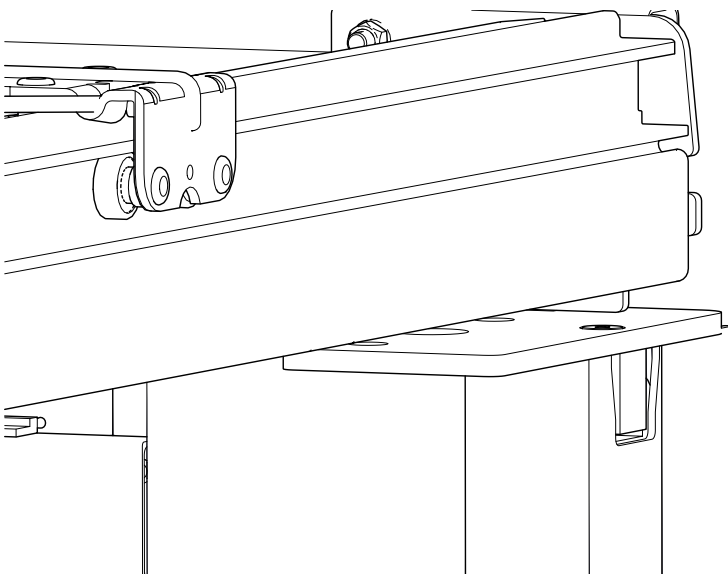
1**Dismantle screws****2****Lift the roof up**

The roof must be lifted so that countersunk screws can be removed.

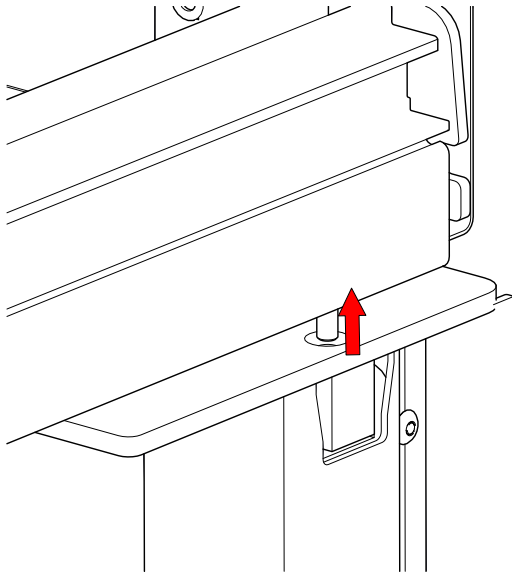
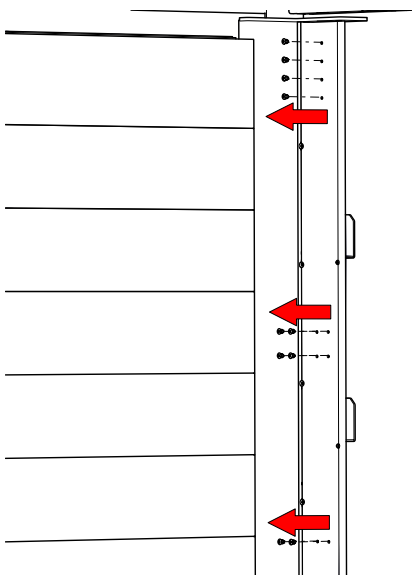
3**Dismantle countersunk screw****4****Dismantle rivets**

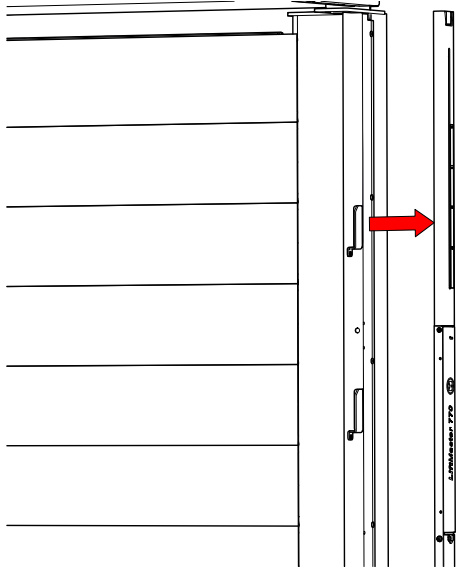
5**Remove Liftmaster**

Mounting of Liftmaster front wall IV

1

Replace Liftmaster

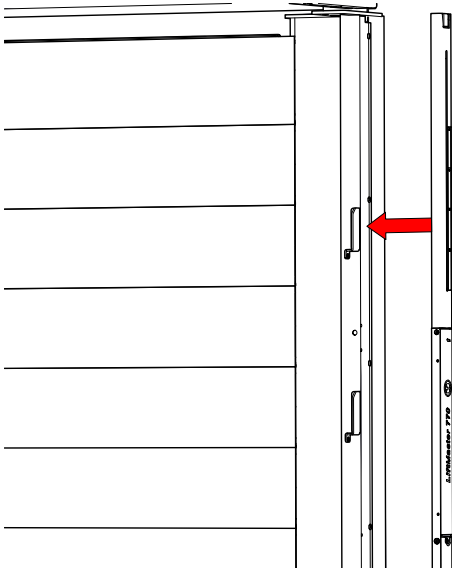

Liftmaster has to be taken
 from Lift system
TSE no.: 1119463

2

Insert rivets

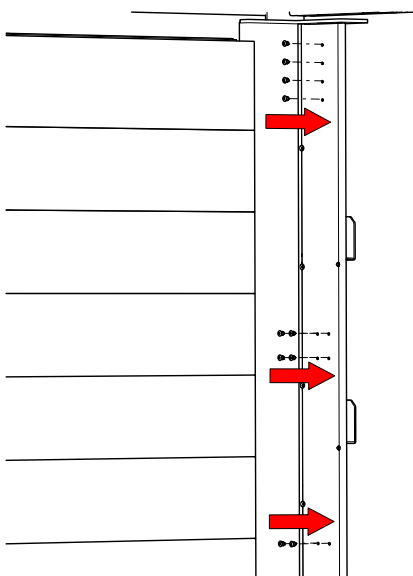

Hemlok rivet
 KL-BER6.8-8.8mm

Hemlok rivet
 KL-BER6.8-8.8mm has to be
 taken from Lift system
TSE no.: 1119463

3

Mount countersunk screw

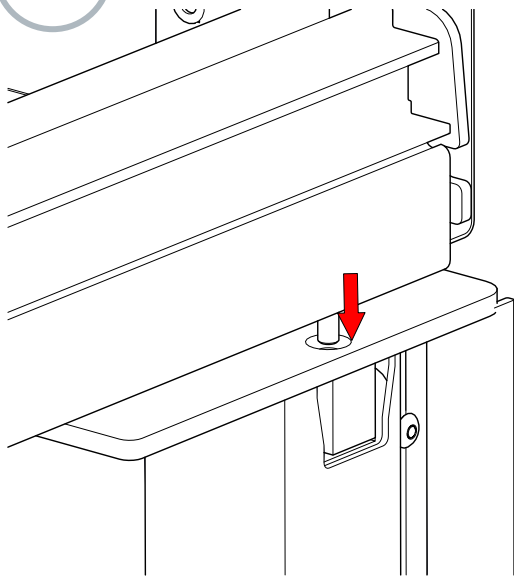

Countersunk screw M8x20

Countersunk screw has to be taken from Lift systems
TSE no.: 1119463



Torque 55.8Nm

4

Mount cylinder screws

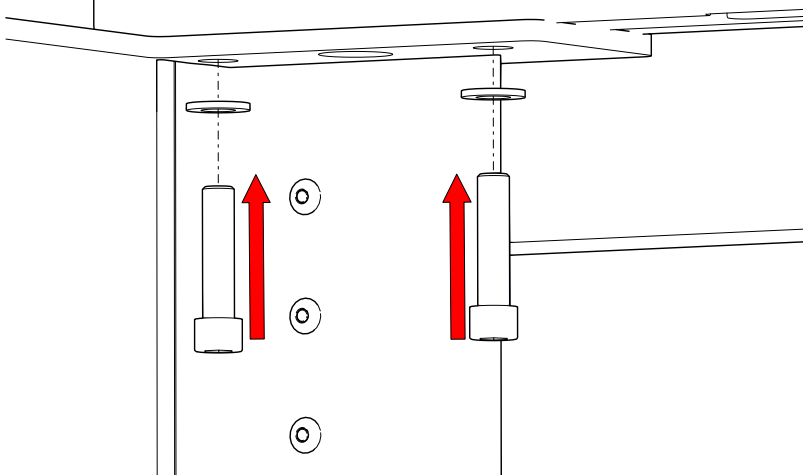

Cylinder screw with internal hex M12x50



Washer A12.5



Torque 130Nm

Dismantling compact hydraulics front wall IV

1

Dismantle screws

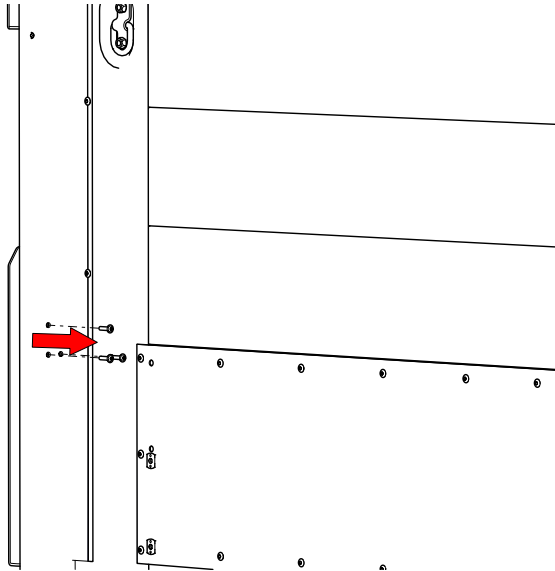

2

Dismantle two ear hose clamp

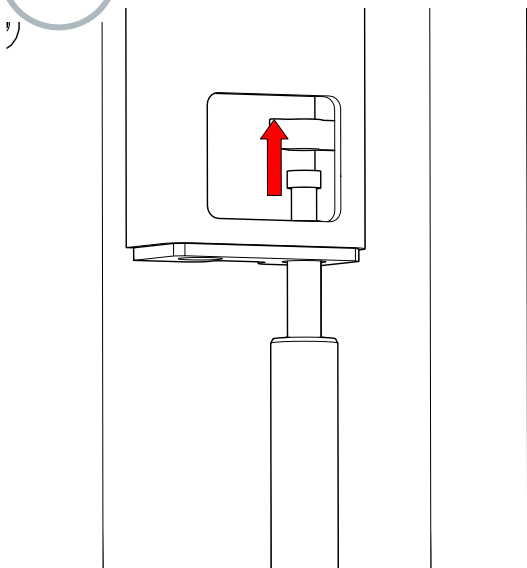

3

Dismantle stanchion lifter

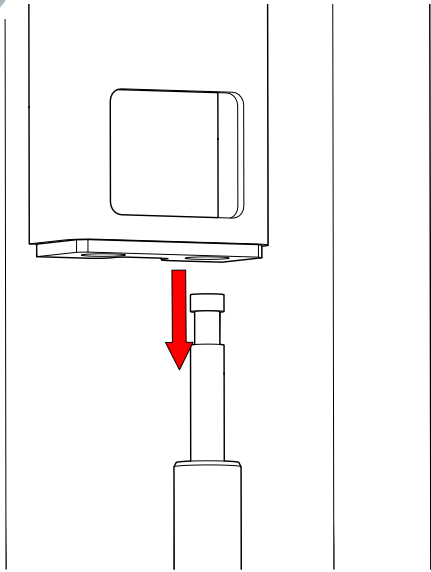

Mounting compact hydraulics front wall IV

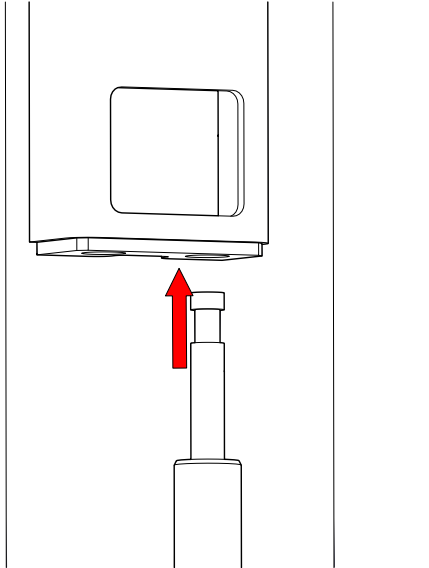
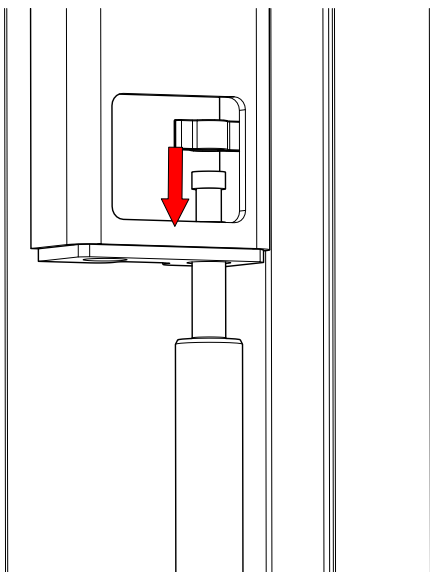
1**Mount stanchion lifter****2****Mount two ear hose clamp**

Two ear hose clamp

Two ear hose clamp has to be
taken from Lift systems
TSE no.: 1250648

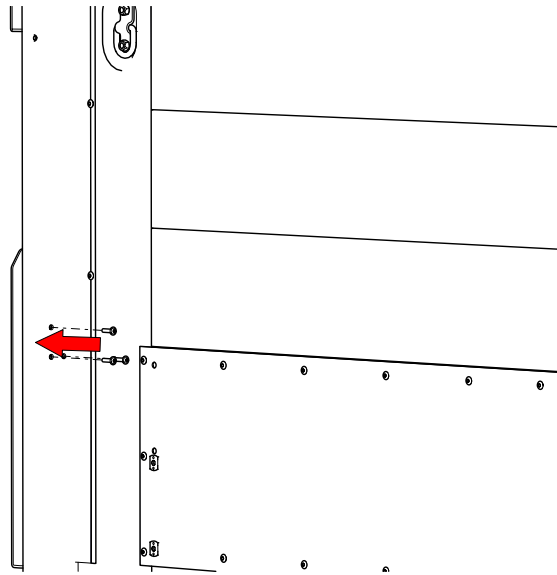
3**Mount fillister head screws**

Fillister head screw M6x25

Stanchion lifter and fillister head screw have to be taken from
Lift system
TSE no.: 1250648

**Torque 22.9Nm**

Ventilation of compact hydraulics

1

After mounting the compact hydraulics

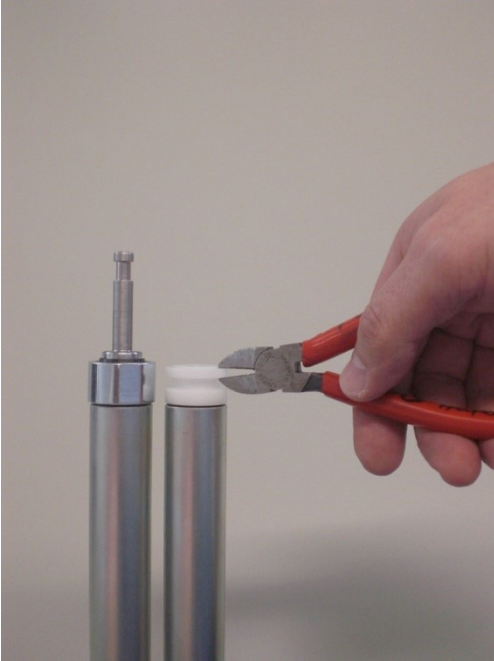

After mounting the compact hydraulics the ventilation of the filler cap must be incised.

Vorspannkraft und Anzugsdrehmomente von Schraubenverbindungen nach VDI- Richtlinie 2230

Abmes- sung	Fertigkeits- klasse	Montagevorspannkraft F_T in kN für $\mu_G =$							Anzugsdrehmomente M_A in Nm für $\mu_K = \mu_G =$						
		0,08	0,10	0,12	0,14	0,16	0,20	0,24	0,08	0,10	0,12	0,14	0,16	0,20	0,24
M 4	8.8	4,6	4,5	4,4	4,3	4,2	3,9	3,7	2,3	2,6	3,0	3,3	3,6	4,1	4,5
	10.9	6,8	6,7	6,5	6,3	6,1	5,7	5,4	3,3	3,9	4,6	4,8	5,3	6,0	6,6
	12.9	8,0	7,8	7,6	7,4	7,1	6,7	6,3	3,9	4,5	5,1	5,6	6,2	7,0	7,8
M 5	8.8	7,6	7,4	7,2	7,0	6,8	6,4	6,0	4,4	5,2	5,9	6,5	7,1	8,1	9,0
	10.9	11,1	10,8	10,6	10,3	10,0	9,4	8,8	6,5	7,6	8,6	9,5	10,4	11,9	13,2
	12.9	13,0	12,7	12,4	12,0	11,7	11,0	10,3	7,6	8,9	10,0	11,2	12,2	14,0	15,5
M 6	8.8	10,7	10,4	10,2	9,9	9,6	9,0	8,4	7,7	9,0	10,1	11,3	12,3	14,1	15,6
	10.9	15,7	15,3	14,9	14,5	14,1	13,2	12,4	11,3	13,2	14,9	16,5	18,0	20,7	22,9
	12.9	18,4	17,9	17,5	17,0	16,5	15,5	14,5	13,2	15,4	17,4	19,3	21,1	24,2	26,8
M 7	8.8	15,5	15,1	14,8	14,4	14,0	13,1	12,3	12,6	14,8	16,8	18,7	20,5	23,6	26,2
	10.9	22,7	22,5	21,7	21,1	20,5	19,3	18,1	18,5	21,7	24,7	27,5	30,1	34,7	38,5
	12.9	26,6	26,0	25,4	24,7	24,0	22,6	21,2	21,6	25,4	28,9	32,2	35,2	40,6	45,1
M 8	8.8	19,5	19,1	18,6	18,1	17,6	16,5	15,5	18,5	21,6	24,6	27,3	29,8	34,3	38,0
	10.9	28,7	28,0	27,3	26,6	25,8	24,3	22,7	27,2	31,8	36,1	40,1	43,8	50,3	55,8
	12.9	33,6	32,8	32,0	31,1	30,2	28,4	26,6	31,8	37,2	42,2	46,9	51,2	58,9	65,3
M10	8.8	31,0	30,3	29,6	28,8	27,9	26,3	24,7	36	43	48	54	59	68	75
	10.9	45,6	44,5	43,4	42,2	41,0	38,6	36,2	53	63	71	79	87	100	110
	12.9	53,3	52,1	50,8	49,4	48,0	45,2	42,4	62	73	83	93	101	116	129
M 12	8.8	45,2	44,1	43,0	41,9	40,7	38,3	35,9	63	73	84	93	102	117	130
	10.9	66,3	64,8	63,2	61,5	59,8	56,3	52,8	92	108	123	137	149	172	191
	12.9	77,6	75,9	74,0	72,0	70,0	65,8	61,8	108	126	144	160	175	201	223
M 14	8.8	62,0	60,6	59,1	57,5	55,9	52,6	49,3	100	117	133	148	162	187	207
	10.9	91,0	88,9	86,7	84,4	82,1	77,2	72,5	146	172	195	218	238	274	304
	12.9	106,5	104,1	101,5	98,8	96,0	90,4	84,8	171	201	229	255	279	321	356
M 16	8.8	84,7	82,9	80,9	78,8	76,6	72,2	67,8	153	180	206	230	252	291	325
	10.9	124,4	121,7	118,8	115,7	112,6	106,1	99,6	224	264	302	338	370	428	477
	12.9	145,5	142,4	139,0	135,4	131,7	124,1	116,6	262	309	354	395	433	501	558
M 18	8.8	107	104	102	99	96	91	85	220	259	295	329	360	415	462
	10.9	152	149	145	141	137	129	121	314	369	421	469	513	592	657
	12.9	178	174	170	165	160	151	142	367	432	492	549	601	692	769
M 20	8.8	136	134	130	127	123	116	109	308	363	415	464	509	588	655
	10.9	194	190	186	181	176	166	156	438	517	592	661	725	838	933
	12.9	227	223	217	212	206	194	182	513	605	692	773	848	980	1092
M 22	8.8	170	166	162	158	154	145	137	417	495	567	634	697	808	901
	10.9	242	237	231	225	219	207	194	595	704	807	904	993	1151	1284
	12.9	283	277	271	264	257	242	228	696	824	945	1057	1162	1347	1502
M 24	8.8	196	192	188	183	173	168	157	529	625	714	798	875	1011	1126
	10.9	280	274	267	260	253	239	224	757	890	1017	1136	1246	1440	1604
	12.9	327	320	313	305	296	279	262	882	1041	1190	1329	1458	1685	1877

Quelle: VDI-Richtlinie 2230 Blatt 1 S. 109

Montagevorspannkraft F_{MTab} und Anzugsdrehmomente M_a bei $\nu = 0,9$ für Schaftschrauben mit metrischem Regelgewinde nach DIN ISO, 68, DIN ISO 724, DIN 13-19; Kopfabmessungen von Sechskantschrauben nach DIN EN ISO 4014 bis DIN EN ISO 4018, Schrauben mit Außensechsrund nach DIN 34 800 bzw. Zylinderschrauben nach DIN EN ISO 4762 und Bohrung „mittel“ nach DIN EN 20 273

Assembly preload F_{MTab} and tightening torque M_a with $\nu = 0,9$ for shank bolts with metric standard thread according to DIN ISO, 68, DIN ISO 724, DIN 13-19; head dimensions of hexagonal bolts according to DIN EN ISO 4014 to DIN EN ISO 4018 hexalobular external driving head bolts according to DIN 34 800 or cylindrical bolts according to DIN EN ISO 4762 and boring „medium“ according to DIN EN 20273

Revision levels

Revision level	Kind of change	Date	Name
00	New creation of repair instruction	13 Feb 2019	Laib / Maier